

PD4-E Modbus RTU



Short instructions
Original: de

Nanotec Electronic GmbH & Co. KG
Kapellenstraße 6
85622 Feldkirchen, Germany

Version 1.0.0
Phone: +49 (89) 900 686-0
Fax: +49 (89) 900 686-50
info@nanotec.de

Introduction

The *PD4-E* is a brushless motor with integrated controller in protection class IP65. The integrated absolute encoder makes immediate operation possible in *closed loop* mode without homing.

This document describes the installation and commissioning of the motor. You can find the detailed documentation for the product and the motor datasheets on the Nanotec website us.nanotec.com. The short instructions do not replace the *technical manual of the product*.

Copyright

Copyright © 2013 – 2018 Nanotec Electronic GmbH & Co. KG. All rights reserved.



Intended use

The *PD4-E* is designed for use under the approved **Environmental conditions**. Any other use is considered unintended use.



Note

Changes or modifications to the product are not permitted.

Warranty and disclaimer

Nanotec produces component parts that are used in a wide range of industrial applications. The selection and use of Nanotec products is the responsibility of the system engineer and end user. Nanotec accepts no responsibility for the integration of the products in the end system.

Under no circumstances may a Nanotec product be integrated as a safety controller in a product or construction. All products containing a component part manufactured by Nanotec must, upon delivery to the end user, be provided with corresponding warning notices and instructions for safe use and safe operation. All warning notices provided by Nanotec must be passed on directly to the end user.

Our general terms and conditions apply: en.nanotec.com/service/general-terms-and-conditions/.

Specialist staff

Only specialists may install, program and commission the device:

- Persons who have appropriate training and experience in work with motors and their control.
- Persons who are familiar with and understand the content of this technical manual.
- Persons who know the applicable regulations.

EU directives for product safety

The following EU directives were observed:

- RoHS directive (2011/65/EU, 2015/863/EU)
- EMC directive (2014/30/EU)

Other applicable regulations

In addition to this technical manual, the following regulations are to be observed:

- Accident-prevention regulations
- Local regulations on occupational safety

Safety and warning notices

Note



- Damage to the controller.
- Changing the wiring during operation may damage the controller.
- Only change the wiring in a de-energized state. After switching off, wait until the capacitors have discharged.

Note



- Fault of the controller due to excitation voltage of the motor.
- Voltage peaks during operation may damage the controller.
- Install suitable circuits (e.g., charging capacitor) that reduce voltage peaks.

Note



- There is no polarity reversal protection.
- Polarity reversal results in a short-circuit between supply voltage and GND (earth) via the power diode.
- Install a line protection device (fuse) in the supply line.

Note



- The device contains components that are sensitive to electrostatic discharge.
- Improper handling can damage the device.
- Observe the basic principles of ESD protection when handling the device.

Technical details and pin assignment

Environmental conditions

Environmental condition	Value
Protection class	IP65 (except for shaft output)
Ambient temperature (operation)	-10 ... +40°C
Air humidity (non-condensing)	0 ... 85%
Altitude of site above <i>sea level</i> (without drop in performance)	1500 m
Ambient temperature (storage)	-25 ... +85°C

Electrical properties and technical data

Technical data – motor

	PD4-E	PD4-EB
Type	High-pole DC servo (stepper motor)	Low-pole DC servo (BLDC)
Operating voltage	12 - 48 V DC ±5%	12 - 48 V DC ±5%
Phase current rms	4.2 A	6 A
Peak current rms for 1 s	N/A	max. 18 A

Technical data

Operating modes	<i>Profile Position Mode, Profile Velocity Mode, Profile Torque Mode, Velocity Mode, Homing Mode, Interpolated Position Mode, Cyclic Sync Position Mode, Cyclic Sync Velocity Mode, Cyclic Synchronous Torque Mode, Clock-Direction Mode</i>
Set value setting / programming	<i>Analog input, NanoJ program</i>
Inputs	6 digital inputs (+5 V/+24 V DC), individually switchable by means of software, factory settings: 5 V 1 analog input 0–10 V or 0–20 mA (switchable by means of software)
Outputs	2 outputs, <i>Open Drain</i> , max. 100 mA
Integrated encoder	Magnetic, single-turn absolute encoder, 1024 pulses/revolution

Protection circuit

Overvoltage and undervoltage protection

Overtemperature protection (> 68°C on rear cover)

Polarity reversal protection: In the event a polarity reversal, a short-circuit will occur between supply voltage and GND over a power diode; a fuse is therefore necessary in the supply line. The values of the fuse are dependent on the application and must be dimensioned

- greater than the maximum current consumption of the controller
- less than the maximum current of the voltage supply.

If the fuse value is very close to the maximum current consumption of the controller, a medium / slow tripping characteristics should be used.

Dimensioned drawings

All dimensions are in millimeters.

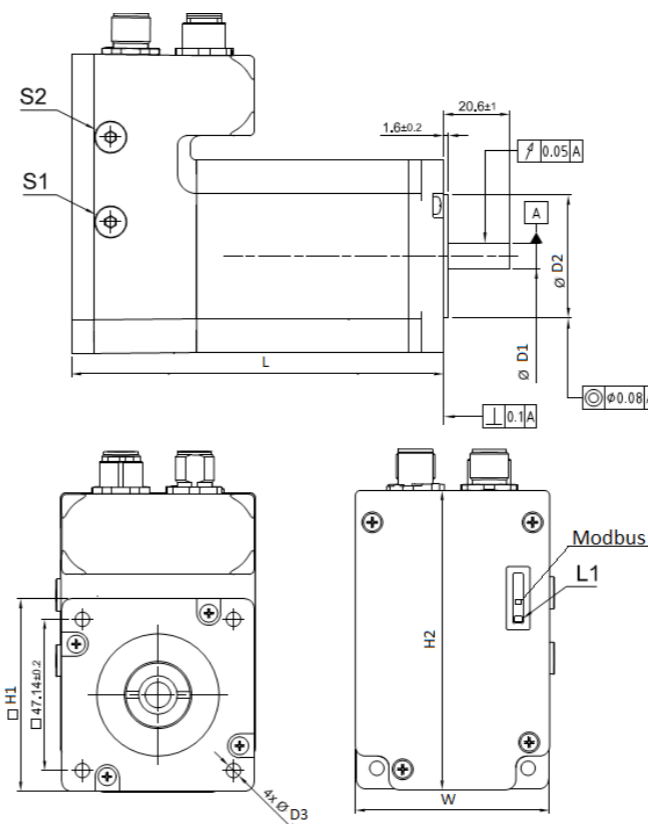

Dimension	Value
L	<ul style="list-style-type: none"> PD4-E591L42-E-65-5: 103±1 PD4-E601L42-E-65-5: 116±1 PD4-EB59CD-E-65-5: 123±1
W	<ul style="list-style-type: none"> PD4-E591L42-E-65-5: 57 PD4-E601L42-E-65-5: 60.6 PD4-EB59CD-E-65-5: 57
H1	<ul style="list-style-type: none"> PD4-E591L42-E-65-5: 56.4±0.5 PD4-E601L42-E-65-5: 60±0.5 PD4-EB59CD-E-65-5: 56.6±0.5
H2	<ul style="list-style-type: none"> PD4-E591L42-E-65-5: 89.7 PD4-E601L42-E-65-5: 93.3 PD4-EB59CD-E-65-5: 89.7
D1	<ul style="list-style-type: none"> PD4-E591L42-E-65-5: 6.35⁺⁰_{-0.013} PD4-E601L42-E-65-5: 8⁺⁰_{-0.015} PD4-EB59CD-E-65-5: 8⁺⁰_{-0.013}
D2	<ul style="list-style-type: none"> PD4-E591L42-E-65-5: 38.1±0.025 PD4-E601L42-E-65-5: 38.1±0.05 PD4-EB59CD-E-65-5: 38.1⁺⁰_{-0.05}

Dimension	Value
D3	<ul style="list-style-type: none"> PD4-E591L42-E-65-5: 5^{+0.5}₋₀ PD4-E601L42-E-65-5: 4.5^{+0.5}₋₀ PD4-EB59CD-E-65-5: 5.2±0.25

Overtemperature protection

Above a temperature of approx. 75°C on the power board (corresponds to 65–72°C outside on the back cover), the power part of the controller switches off and the error bit is set. After cooling down and confirming the error, the controller again functions normally.

LED signaling

Power LED

Normal operation

In normal operation, the green power LED L1 flashes briefly once per second.

Case of an error

If an error has occurred, the LED turns red and signals an error number.

The following table shows the meaning of the error numbers.

Flash rate	Error
1	General
2	Voltage
3	Temperature
4	Overcurrent
5	Controller
6	Watchdog-Reset



Note

For each error that occurs, a more precise error code is stored in object **1003_h**.

Pin assignment

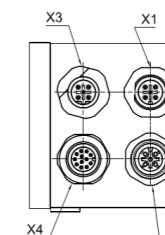

Connector	Function	Pin assignment / description
X1	Modbus RTU IN	1. n.c: Pin 1 of X1 and X2 internally connected
X2	Modbus RTU OUT	2. RS-485- 3. COMMON GND : electrically isolated from the GND of the main supply 4. RS-485+ 5. n.c
X3	Voltage supply 12 - 48 V DC ±5%	1. +Ub 2. +Ub 3. GND 4. GND 5. n.c

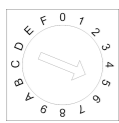
Connector	Function	Pin assignment / description												
X4	Inputs/outputs and external logic supply Switching thresholds for digital inputs 1 - 6: 5 V (factory setting): On: >4.09 V; Off: <0.95 V 24 V: On: >14.74 V; Off: <3.78 V	<ol style="list-style-type: none"> GND Digital input 1: 5 V / 24 V, switchable with object 3240_h, max. 1 MHz Digital input 2: 5 V / 24 V, switchable with object 3240_h, max. 1 MHz Digital input 3: 5 V / 24 V, switchable with object 3240_h, max. 1 MHz Digital input 4: 5 V / 24 V, switchable with object 3240_h, max. 1 MHz Digital input 5: 5 V / 24 V, switchable with object 3240_h, max. 1 MHz Digital input 6: 5 V / 24 V, switchable with object 3240_h, max. 1 MHz Analog input: 10 Bit, 0-10 V or 0-20 mA, switchable with object 3221_h Digital output 1: Open drain, max 24 V/100 mA Digital output 2: Open drain, max 24 V/100 mA 5V output: +5 VDC, max. 100 mA +UB Logic: 4 V DC/approx. 39 mA 												
S1	Hex coding switch for setting the Modbus address and baud rate: 	<table border="1"> <thead> <tr> <th>Value of the switch</th> <th>Address</th> <th>Baud rate / Parity</th> </tr> </thead> <tbody> <tr> <td>0_h</td> <td>Object 2028_h</td> <td>Objekt 202A_h / 202D_h</td> </tr> <tr> <td>1-E_h</td> <td>Value of the switch</td> <td>Objekt 202A_h / 202D_h</td> </tr> <tr> <td>F_h</td> <td>5</td> <td>19200, even Parity</td> </tr> </tbody> </table>	Value of the switch	Address	Baud rate / Parity	0 _h	Object 2028 _h	Objekt 202A _h / 202D _h	1-E _h	Value of the switch	Objekt 202A _h / 202D _h	F _h	5	19200, even Parity
Value of the switch	Address	Baud rate / Parity												
0 _h	Object 2028 _h	Objekt 202A _h / 202D _h												
1-E _h	Value of the switch	Objekt 202A _h / 202D _h												
F _h	5	19200, even Parity												
S2	DIP switch for 150 Ω termination for RS-485	OFF ON (left)												

If you set 3240_h:07_h to the value "1", three differential inputs are available instead of six single-ended inputs.

Pin	Basic function		Alternative function	
	Single-ended	Differential	Single-ended	Differential
2	Input 1	- Input 1	Enable	-Enable
3	Input 2 / Direction input	+ Input 1	Direction	Enable
4	Input 3 / clock input	- Input 2 / - Direction input	Clock	-Direction
5	Input 4	+ Input 2 / + Direction input	Digital input 4	Direction
6	Input 5	- Input 3 / - Clock input	Digital input 5	-Clock
7	Input 6	+ Input 3 / + Clock input	Digital input 6	Clock

Note

- EMC: For a DC power supply line longer than 30 m or when using the motor on a DC bus, additional interference-suppression and protection measures are necessary.
- An EMI filter is to be inserted in the DC supply line as close as possible to the controller/motor.
- Long data or supply lines are to be routed through ferrites.

Commissioning

The *Plug & Drive Studio* software offers you an option for performing the configuration and adapting the motor parameters to your application. You can find further information in document *Plug & Drive Studio: Quick Start Guide* at us.nanotec.com.

Observe the following notes:

CAUTION



Moving parts can cause hand injuries.

If you touch moving parts during running operation, hand injuries may result.

- Do not reach for moving parts during operation. After switching off, wait until all movements have ended.

CAUTION



In free-standing operation, motor movements are uncontrolled and can cause injuries.

If the motor is unsecured, it can, e.g., fall down. Foot injuries or damage to the motor could occur.

- If you operate the motor free-standing, observe the motor, switch it off immediately in the event of danger and make certain that the motor cannot fall down.

CAUTION



Moving parts can catch hair and loose clothing.

During running operation, moving parts can catch hair or loose clothing, which may lead to injuries.

- If you have long hair, wear a hairnet or take other suitable protective measures when near moving parts. Do not work with loose clothing or ties near moving parts.

CAUTION



Risk of overheating or fire if there is insufficient cooling!

If cooling is insufficient or if the ambient temperature is too high, there is a risk of overheating or fire.

- During use, make certain that the cooling and environmental conditions are ensured.

Note

- EMC: Current-carrying cables – particularly around supply and motor cables – produce electromagnetic alternating fields.
- These can interfere with the motor and other devices. Nanotec recommends the following measures:
 - Use shielded cables and earth the cable shielding on both ends over a short distance.
 - Use cables with cores in twisted pairs.
 - Keep power supply and motor cables as short as possible.
 - Earth motor housing with large contact area over a short distance.
 - Lay supply, motor and control cables physically separate from one another.

Establishing communication via Modbus

- Connect the *Modbus master* to the controller via the RS-485+ and RS-485- cables.
- Supply the controller with voltage.
- Change the configuration values if necessary.
The controller is set to slave address 1 ex works, baud rate 19200 baud, even parity, 1 stop bit.
- To test the interface, send bytes 01 65 55 00 2E 97 to the controller (you can find a detailed description of the Modbus function codes in chapter **Modbus RTU** of the *technical manual*).
The object dictionary is read out.

Special drive modes (clock-direction and analog speed)

You have the possibility to control the motor directly via the clock and direction input or the analog input by activating the *special drive modes*.

Digital input 1 serves here as an enable.

Activation

To activate the *special drive modes*, you must enter the value "2" in 4015_h:01_h. In 4015_h:02_h, set the mode by writing a value between "00"_h and "0F"_h.

The following table lists all possible modes and their value for 4015:02_h:

Value	Mode
00 _h /01 _h	Clock-direction
-	-
-	Open Loop

Value	Mode
02 _h	Test run
03 _h	Test run
04 _h	Analog speed
05 _h	Analog speed
06 _h	Analog speed
07 _h	Analog speed
08 _h /09 _h	Clock-direction
0A _h	Test run
0B _h	Test run
0C _h	Analog speed
0D _h	Analog speed
0E _h	Analog speed
0F _h	Analog speed

You must save object 4015_h (*application category*); by writing the value "65766173" in 1010_h:03_h, the changes do not take effect until after the controller is restarted.

Clock-direction

The controller internally sets the operating mode to **clock-direction**. You must connect the *enable*, *clock* and *direction* inputs .

Analog speed

The controller internally sets the operating mode to **Velocity**. To preset the speed, the voltage on the analog input is used and the corresponding target speed is written in 6042_h.

Maximum speed

The maximum speed can be changed between 100 rpm and 1000 rpm. If a different speed is necessary, it can be set using the scaling factor (object 604C_h, subindices 01_h and 02_h).

Computation of the analog voltage

There are two modes for calculating the analog input voltage.

Normal mode

You must connect the *enable*, *direction* and *analog inputs*. The maximum analog voltage corresponds to the maximum speed. The direction is preset here via the direction input. There is a dead zone from 0 V to 20 mV in which the motor does not move.

Joystick mode

You must connect the *release input* and the *analog input*. Half of the maximum analog voltage corresponds to the speed 0. If the voltage drops below half, the speed increases in the negative direction. If the speed rises above half, the speed increases likewise in the positive direction. The dead zone here extends from $U_{max}/2 \pm 20$ mV.

Test run with 30 rpm

The motor rotates at 30 rpm if the *enable input* is set.

Installation

You can find the dimensions needed for the mounting of the motor in **Dimensioned drawings**.

In order to mount the motor proceed as follows:

- Align the motor shaft with the shaft of the application. Pay attention to the permissible axial and radial forces on the shaft, which you are indicated in the datasheet of the corresponding motor.
- Attach the motor to your mechanics using the four mounting bores.
Use screws of suitable length and matching washers.