

Front view and mounting

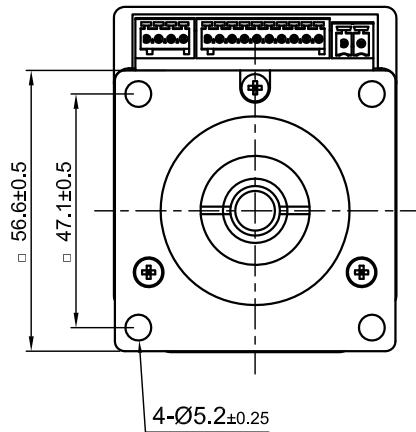

Side view

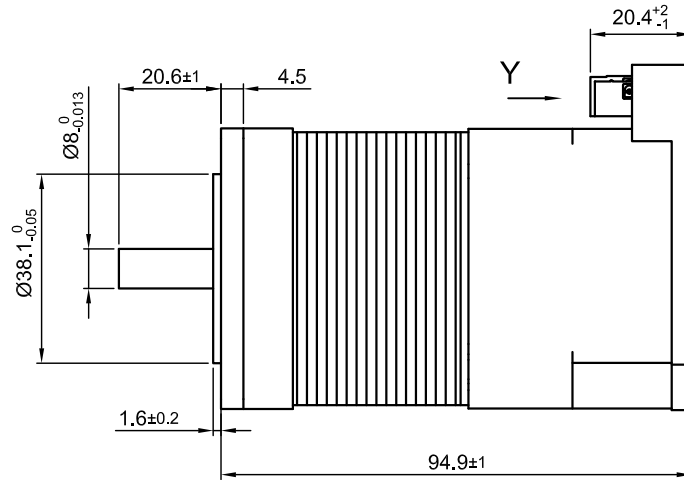

Rear view

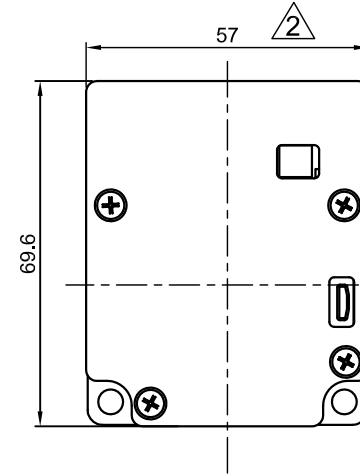

Y view

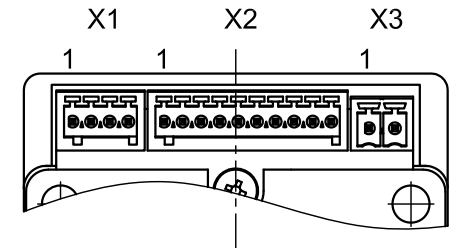

SPECIFICATION	CONNECTION	STAR \triangle
NO. OF POL./PHASE		6/3
VOLTAGE RATED (VDC)		24
CURRENT RATED/PEAK (A)		8/20
TORQUE RATED/PEAK (Nm)		0.37/0.92
TORQUE CONSTANT (Nm/A)		0.046
BACK EMF(Vrms/Krpm)		3.8
POWER RATED (W)		135
SPEED RATED/NO LOAD (RPM)		3500±10%/4500±10% \triangle \triangle
WEIGHT (Kg)		0.87

PERMISSIBLE RADIAL+AXIAL FORCE

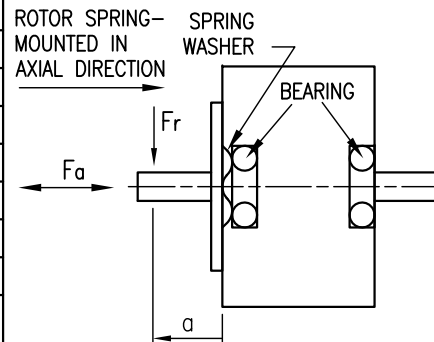

OVERTEMPERATURE PROTECTION (ELECTRONICS): 75°C \triangle		
AMBIENT TEMPERATURE -10°~ 50°C [14°F ~ 122°F] (HIGHER TEMPERATURE REDUCES DUTY CYCLE)		
INSULATION RESISTANCE 100 MΩ (UNDER NORMAL TEMPERATURE AND HUMIDITY)		
INSULATION CLASS B 130° [266°F]		
DIELECTRIC STRENGTH 500VAC FOR 1 MIN. (BETWEEN THE MOTOR COILS AND THE MOTOR CASE)		
AMBIENT HUMIDITY MAX. 85% (NO CONDENSATION)		

AXIAL-FORCE Fa (N)	15	
DISTANCE a (mm)	20	
RADIAL-FORCE Fr (N)	75	
	AXIAL	RADIAL
SHAFT PLAY (mm)	-0.1Max	0.025
AT LOAD MAX: (N)	40	4.6

X1, Phoenix MCV-04

PIN No.	Function
1	GND
2	Analog Input(0-10V)
3	Output (open drain)
4	+12V (Voltage Output, max.100mA)

X2, Phoenix MCV-10

PIN No.	Function
1	Input1 (+24V)
2	Input2 (+24V)
3	Input3 (+24V)
4	-Enable +5/+24V
5	Enable +5/+24V
6	-Direction +5/+24V
7	Direction +5/+24V
8	-Clock +5/+24V
9	Clock +5/+24V
10	GND

X3, Phoenix FMC-02

PIN No.	Function
1	+VCC(12-24V)
2	GND

4	NEW NO LOAD SPEED	21.04.22	GYQ	Nanotec PLUG & DRIVE	APVD	G.M.	05.08.13		
3	NEW NO LOAD SPEED	30.11.18	GYQ		CHKD				
2	REWORK DRAW/UPDATE DATA	19.07.16	GYQ	Surface specification DIN ISO 1302	General tolerances DIN ISO 2768-cH	Work piece edge DIN ISO 13715	DRN	GYQ	05.08.13
REV	DESCRIPTION	DATE	DRN				SIGNATURE		DATE

PLUG&DRIVE MOTOR

DWG.NO
PD4-CB59M024035-E-01