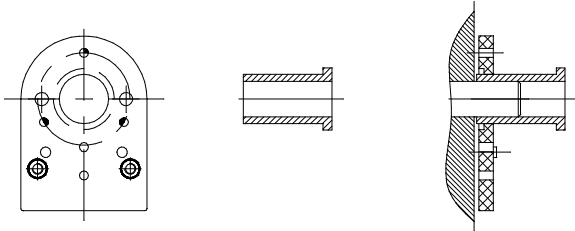
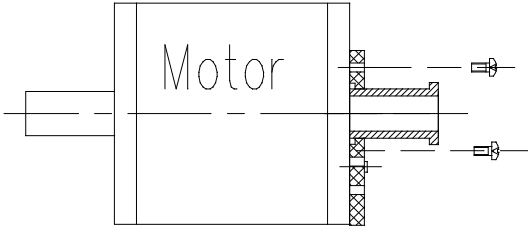

Diagram of the installation procedure

start



1. Fixed position concentricity(Motor shaft, Allocation barrel, Allocation mould)



2. Fix the allocation mould with screw

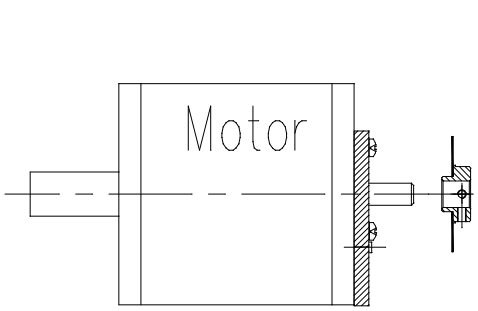
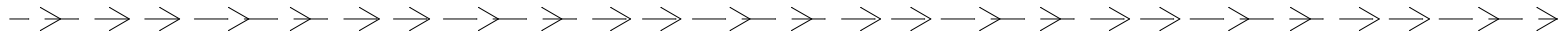

3. Install the code-wheel

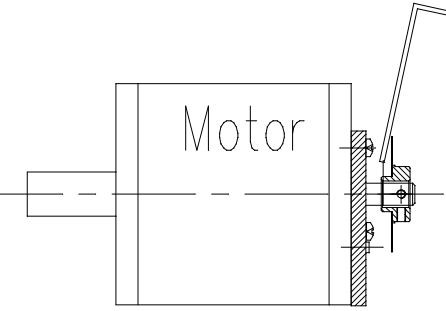

4. Fix the code-wheel with screw (not too tight)

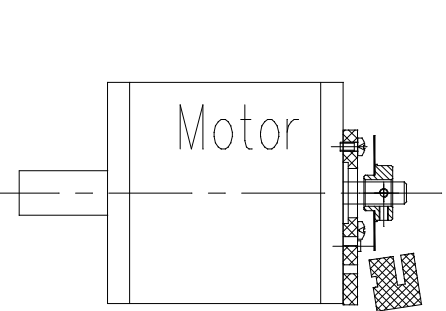

5. Install the encoder module

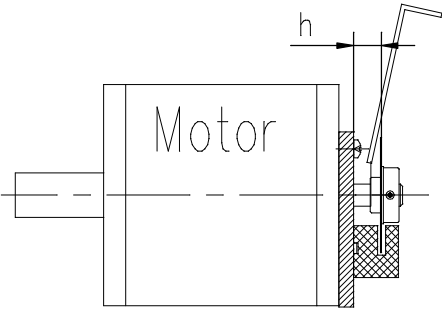
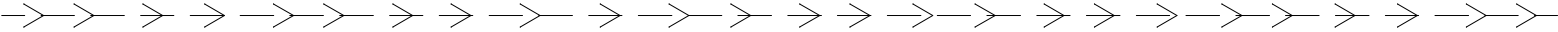

6. Fix the code-wheel(check the code-wheel in the middle of the clearance)

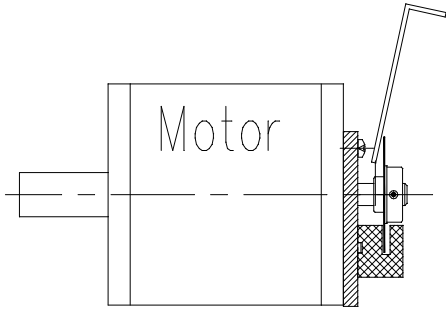

7. Fix the code-wheel(screw down)

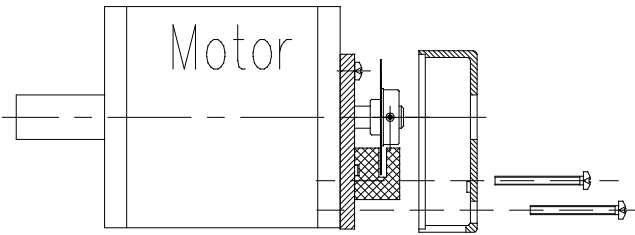
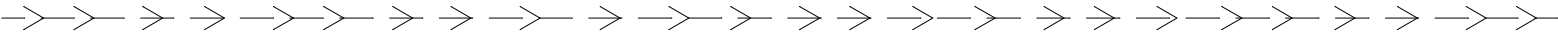

8. Install the housing

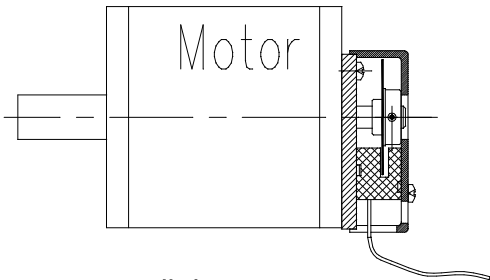

9. Install the connector

