

# Technical Datasheet

## NME2

For use with the following devices:

NME2-UVW, NME2-SSI

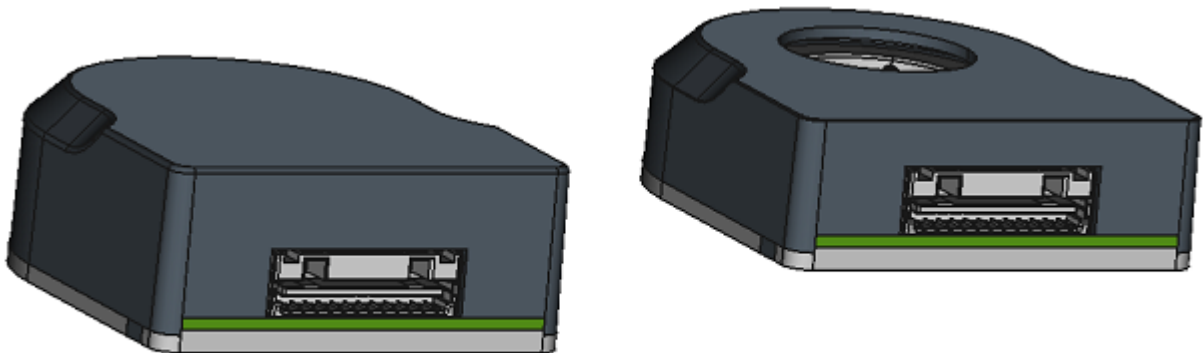

# Contents

<b>1 Introduction.....</b>	<b>3</b>
1.1 Variants and article numbers.....	3
1.2 Version information.....	4
1.3 Copyright, marking and contact.....	4
1.4 Intended use.....	4
1.5 Warranty and disclaimer.....	4
1.6 Target group and qualification.....	5
1.7 EU directives for product safety.....	5
1.8 Used icons.....	5
1.9 Emphasis in the text.....	5
<b>2 Safety and warning notices.....</b>	<b>6</b>
<b>3 Technical details and pin assignment.....</b>	<b>7</b>
3.1 Environmental conditions.....	7
3.2 Dimensioned drawings.....	7
3.3 Electrical properties and technical data.....	8
3.4 Pin assignment.....	8
3.5 Output signals.....	11

# 1 Introduction

The *NME2* is a magnetic rotary encoder for detecting the rotor position of motors. The attachment to a motor and parameterization/calibration are performed by Nanotec.

This data sheet contains the technical data of the encoder and describes its function. You can find information on the combination possibilities with Nanotec motors and other mechanical drawings at [us.nanotec.com](http://us.nanotec.com).

## 1.1 Variants and article numbers

The following figure shows the article number key for the variants of the *NME2*:

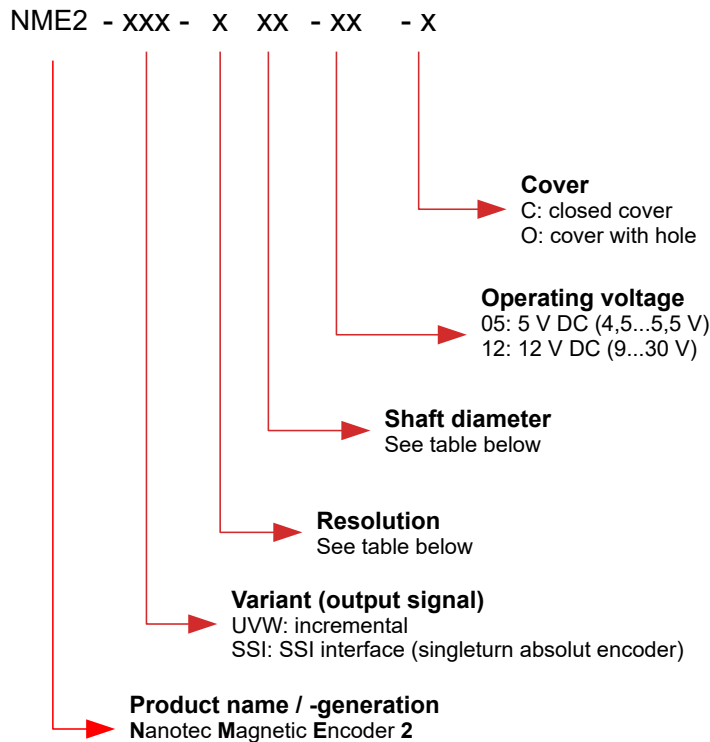

Letter	Resolution [CPR]
U	$2^{16}$ (65536 [PPR] with quadrature)
V	$2^{17}$ (131072 [PPR])
W	$2^{12}$ (16384 [PPR] with quadrature)

Number	Shaft diameter of the motor
14	5 mm
06	6.35 mm
13	8 mm
10	10 mm
15	15 mm

## 1.2 Version information

Data sheet version	Date	Changes	Hardware version
1.0.0	06/2020	Edition	W002
1.0.1	03/2021	<ul style="list-style-type: none"> <li>■ max. permissible altitude removed</li> <li>■ SSI output signals level added</li> </ul>	W002
1.0.2	08/2021	New variants with 4096 [CPR] added.	W002

## 1.3 Copyright, marking and contact

© 2021 Nanotec Electronic GmbH & Co. KG. All rights reserved.

Nanotec Electronic GmbH & Co. KG

Kapellenstraße 6

85622 Feldkirchen

Germany

Phone: +49 89 900 686-0

Fax: +49 (89) 900 686-50

[us.nanotec.com](http://us.nanotec.com)

## 1.4 Intended use

The *NME2* is used as a component of drive systems in a range of industrial applications.

Use the product as intended within the limits defined in the technical data (see [Electrical properties and technical data](#)) and the approved [Environmental conditions](#).

Under no circumstances may this Nanotec product be integrated as a safety component in a product or system. All products containing a component manufactured by Nanotec must, upon delivery to the end user, be provided with corresponding warning notices and instructions for safe use and safe operation. All warning notices provided by Nanotec must be passed on directly to the end user.

## 1.5 Warranty and disclaimer

Nanotec assumes no liability for damages and malfunctions resulting from installation errors, failure to observe this manual or improper repairs. The selection and use of Nanotec products is the responsibility of the plant engineer or end user. Nanotec accepts no responsibility for the integration of the product in the end system.

Our general terms and conditions at [www.nanotec.com](http://www.nanotec.com) apply.

Customers of Nanotec Electronic US Inc. please refer to [us.nanotec.com](http://us.nanotec.com).



### NOTE

Changes or modifications to the product are not permitted.

## 1.6 Target group and qualification

The product and this documentation are directed towards technically trained specialists staff such as:

- Development engineers
- Plant engineers
- Installers/service personnel
- Application engineers

Only specialists may install and commission the product. Specialist staff are persons who

- have appropriate training and experience in work with motors and their control,
- are familiar with and understand the content of this technical manual,
- know the applicable regulations.



## 1.7 EU directives for product safety

The following EU directives were observed:

- RoHS directive (2011/65/EU, 2015/863/EU)

## 1.8 Used icons

All notices are in the same format. The degree of the hazard is divided into the following classes.

<b>CAUTION</b>	
	<p><b>The CAUTION notice indicates a possibly dangerous situation.</b></p> <p>Failure to observe the notice <b>may</b> result in moderately severe injuries.</p> <p>▶ Describes how you can avoid the dangerous situation.</p>
<b>NOTE</b>	
	<p><b>Indicates a possible incorrect operation of the product.</b></p> <p>Failure to observe the notice may result in damage to this or other products.</p> <p>▶ Describes how you can avoid the incorrect operation.</p>
<b>TIP</b>	
	<p>Shows a tip for the application or task.</p>

## 1.9 Emphasis in the text

The following conventions are used in the document:

Underlined text indicates cross references and hyperlinks:

- Use the product as intended within the limits defined by the technical data (see Electrical properties and technical data)
- and under the approved Environmental conditions.

Text set in *italics* marks named objects:

- The *NME2* is an external magnetic encoder for detecting the rotor position of motors.

## 2 Safety and warning notices

### NOTE



#### **Damage to the electronics through improper handling of ESD-sensitive components!**

The device contains components that are sensitive to electrostatic discharge. Improper handling can damage the device.

- ▶ Observe the basic principles of ESD protection when handling the device.
- 

### NOTE



#### **Damage to the electronics by connecting the supply voltage with wrong polarity.**

Reverse polarity protection is not provided.

- ▶ Observe the pin assignment and use a connector plug of the appropriate type.
-

## 3 Technical details and pin assignment

### 3.1 Environmental conditions

Environmental condition	Value
Protection class according to EN/IEC 60529	IP30
Ambient temperature (operation)	-25... +105°C
Ambient temperature (storage)	-25... +105°C
Air humidity (non-condensing)	0 ... 95%

### 3.2 Dimensioned drawings

All dimensions are in millimeters.

NME2-xxx-xxx-xx-C (with closed cover):

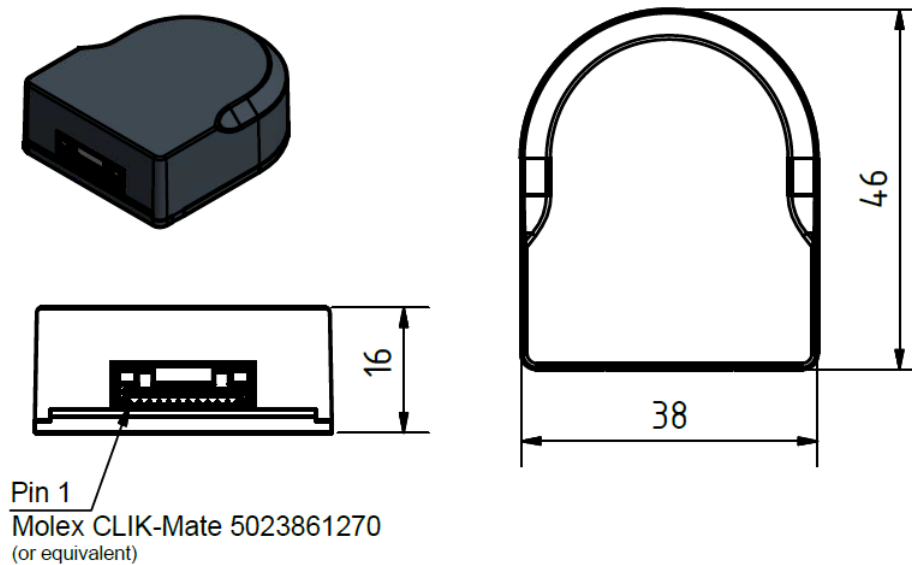

NME2-xxx-x10-xx-O (hole with diameter of 12 mm) and NME2-xxx-x15-xx-O (hole with diameter of 17 mm):

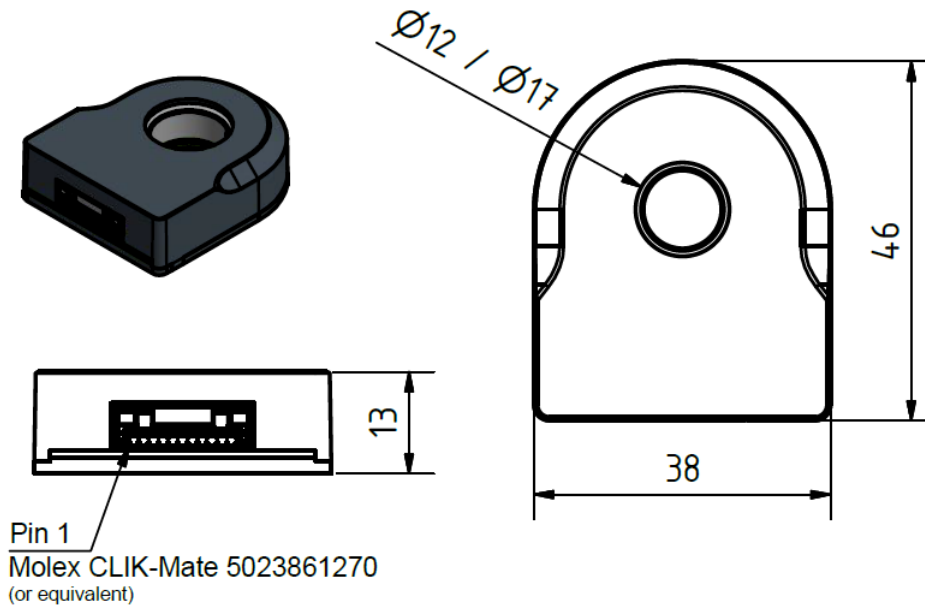

### 3.3 Electrical properties and technical data

Property	Description / value
Operating voltage	<ul style="list-style-type: none"> <li>■ NME2-xxx-xxx-05-x: 4.5 ... 5.5 V DC</li> <li>■ NME2-xxx-xxx-12-x: 9 ... 30 V DC</li> </ul>
Typical current consumption (without load)	<ul style="list-style-type: none"> <li>■ NME2-xxx-xxx-05-x: 50 mA @5 V</li> <li>■ NME2-xxx-xxx-12-x: 40 mA @12 V</li> </ul>
Resolution (CPR – without quadrature)	<ul style="list-style-type: none"> <li>■ NME2-xxx-Uxx-xx-x: 2<sup>16</sup> (65536) positions per mechanical revolution with quadrature (16384 [CPR] without quadrature)</li> <li>■ NME2-xxx-Vxx-xx-x: 2<sup>17</sup> (131072) positions per mechanical revolution</li> <li>■ NME2-xxx-Wxx-xx-x: 2<sup>14</sup> (16384) positions per mechanical revolution with quadrature (4096 [CPR] without quadrature)</li> </ul>
Maximum mechanical speed	12000 revolutions/minute

### 3.4 Pin assignment

- Type: Molex CLIK-Mate 5023861270
- Mating connector (not included in scope of delivery):
  - Housing: Molex CLIK-Mate 5023801200 (or equivalent)
  - Contacts: Molex CLIK-Mate 5023810000 (or equivalent)
- Suitable Nanotec cable: ZK-NME2-12-500-S



In the following figure, pin 1 is marked.

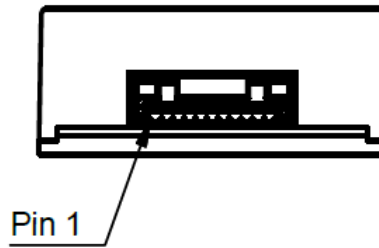

**Incremental encoder**

The following pin assignment applies for the variants with incremental output signals (NME2-UVW-xxx-xx-x):

Pin	Function	Note
1	Ub	For connection for the supply voltage, see <a href="#">Electrical properties and technical data</a>
2	A\	
3	A	
4	B\	
5	B	
6	I\	
7	I	
8	Hall 1	with BLDC motors only
9	Hall 2	with BLDC motors only
10	Hall 3	with BLDC motors only
11	Preset	See <a href="#">Preset function</a>
12	GND	not connected to motor housing

The following signal levels (Ub =5 V, load = 20 mA) apply for differential encoder signals A, A\, B, B\, I, I\ of variants NME2-UVW-xxx-xx-x:

High level	Low level
≥ 2.4 V	≥ 0.4 V

The following signal levels (Ub = 5 V, load = 4 mA) apply for Hall sensors Hall 1, Hall 2, Hall 3 of variants NME2-UVW-xxx-xx-x (only present with BLDC motors):

High level (Ub = 4.5 V)	Low level (Ub = 4.5-5.5 V)
≥ 4 V	≥ 0.5 V

**SSI encoder**

The following pin assignment applies for the variants with SS interface (NME2-SSI-xxx-xx-x):

Pin	Function	Note
1	Ub	For connection for the supply voltage, see <a href="#">Electrical properties and technical data</a>
2	Clock +	see <a href="#">SSI output signals</a> 120 ohm termination resistor between clock + clock - internal
3	Clock -	see <a href="#">SSI output signals</a> 120 ohm termination resistor between clock + clock - internal
4	Data OUT +	see <a href="#">SSI output signals</a>
5	Data OUT -	see <a href="#">SSI output signals</a>
6	n.c	
7	n.c	
8	n.c	
9	n.c	
10	n.c	
11	Preset	See <a href="#">Preset function</a>
12	GND	not connected to motor housing

### Preset function

With the preset function, you can set the internal index or the zero position of the encoder to a new position. The electronics of the encoder then stores this position and in the future then outputs the index signal or the zero position at this position.

#### CAUTION



#### Uncontrolled motor movements!

- ▶ Switch off the control before you trigger the preset function.
- ▶ Restart your controller after the preset and, if necessary, recalibrate or perform another auto setup before switching the drive back to control operation.

To define the new index or zero position, proceed as follows:

1. Move to the desired position with the motor.
2. Trigger the preset function by applying the supply voltage of the encoder to pin 11 (preset). The voltage should be applied for at least 3 seconds.
3. Switch off the power supply of the encoder.  
The next time the encoder is switched on, it outputs the index signal at this position (zero position).

### 3.5 Output signals

#### Incremental output signals (NME2-UVW-xxx-xx-x)

Clockwise when viewing the drive shaft of the motor, the signal of channel A leads channel B by 90° (electrical). The index signal has a width of 90° and is synchronized with the edge of channel A:

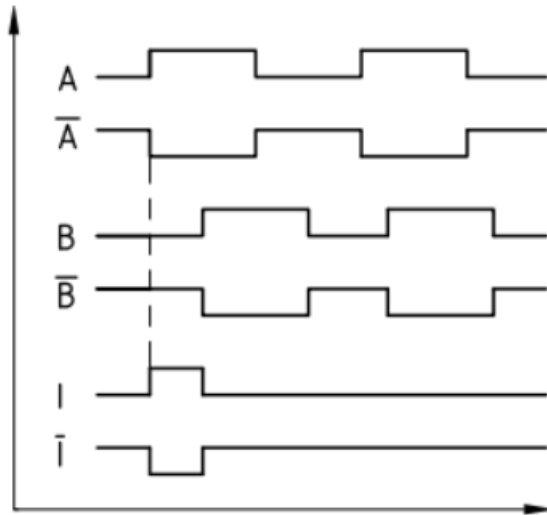

The Hall signals (preconfigured only if attached to BLDC motors) are arranged so that the rising and falling edges of Hall 1 lie at the zero crossings of the back-EMF voltage  $U_{w,u}$  (voltage of phase W after phase U of the BLDC motor):

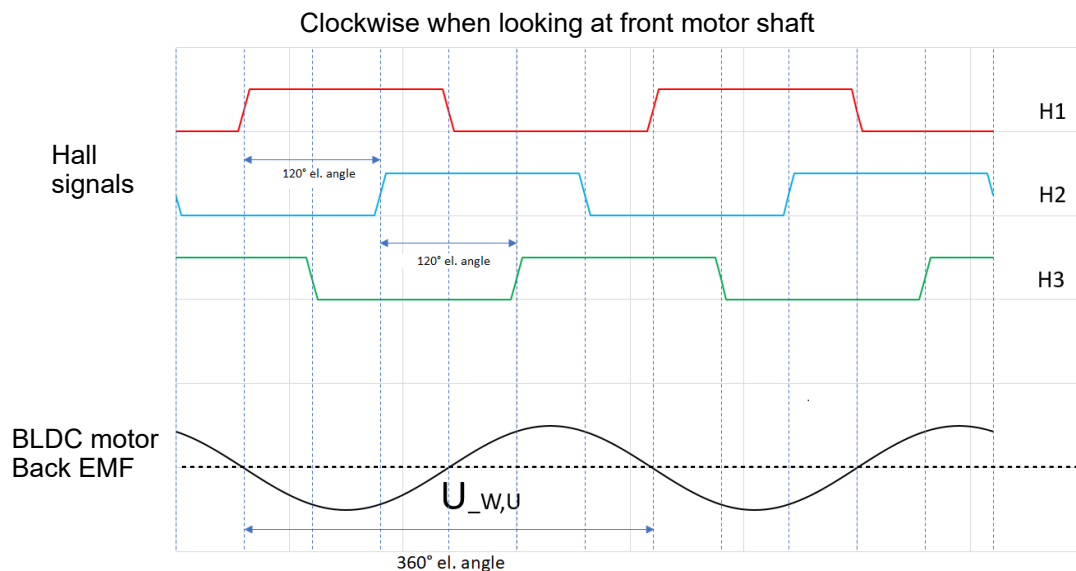

### SSI output signals (NME2-SSI-xxx-xx-x)

The signals of the SSI interface are RS-485/422 compatible (differential transfer) with 5 V TTL level. Clock frequencies of up to 10 MHz are supported for the clock signal.

The following figure shows the signal curve:

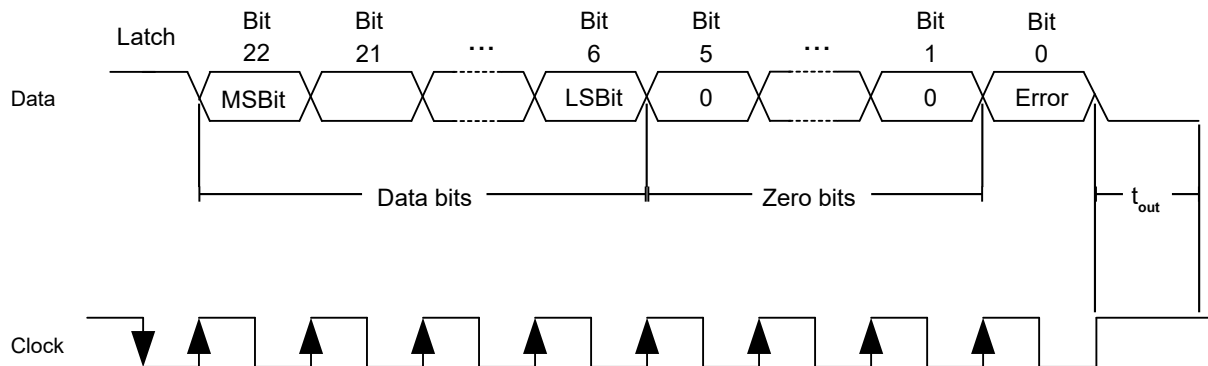

The message is binary-encoded and consists of a total of 24 bits (3 bytes):

#### Latch

Data transfer begins with the first falling edge of the clock signal; the first bit is always 1.

#### Data bits (position value)

Transfer of the position at the current moment begins with the next rising edge of the clock signal.

The data (17 bits) are sent with the highest value bit (MSB) first. Each bit is sent with a rising edge of the clock signal.

#### Zero bits

The data bits are followed by five zero bits.

#### Error bit

The last bit indicates whether (bit is "0") or not (bit is "1") an internal error has occurred.

After a timeout ( $t_{out}$ ) of 20  $\mu$ s, a new data packet can be requested via the clock signal.

If attached to BLDC motors, the absolute zero position of the encoder is programmed so that it lies at the zero crossing of the back-EMF voltage  $U_{w, u}$  (voltage of phase W after phase U of the BLDC motor).