

Front view and mounting

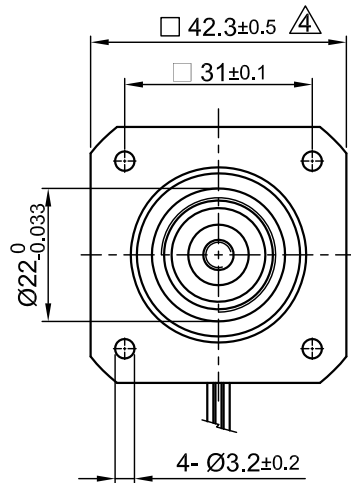

Side view

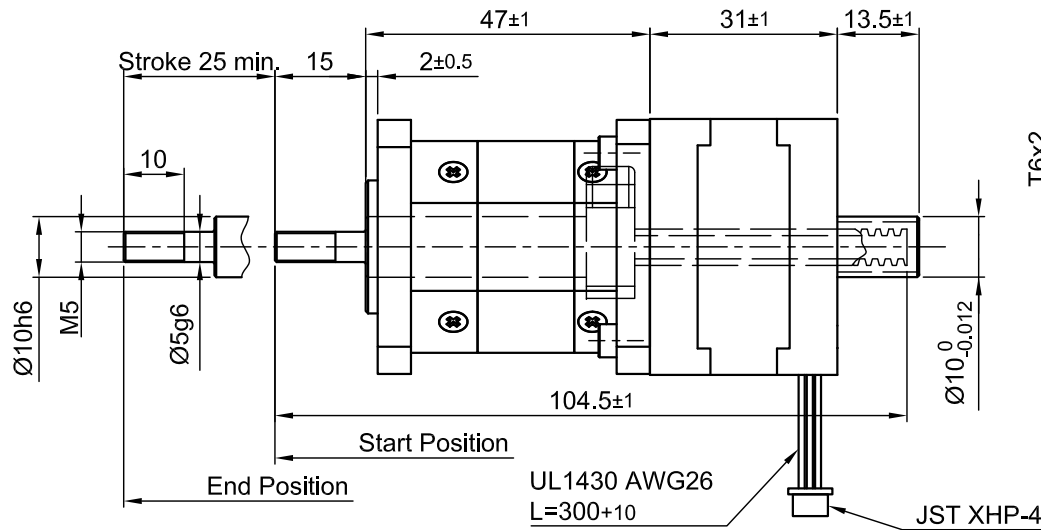

Rear view

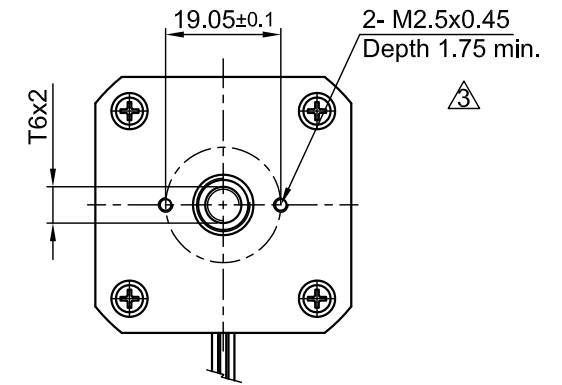

SPECIFICATION

AMPS/PHASE	1.4
RESISTANCE/PHASE (Ohms)@25°C	2.0±15%
INDUCTANCE/PHASE (mH) @1KHz	2.8±20%
SPINDLE PITCH (mm) [in]	2 [0.079]
THRUST (N)	250
RESOLUTION (mm/FULLSTEP)	0.010
STATIC THRUST (N) (NO CURRENT)	300
MAX. SPEED (mm/sec.) AT 48V	55
WEIGHT (Kg) [lb]	0.35 [0.77]
TEMPERATURE RISE: MAX.80°C (MOTOR STANDSTILL; FOR 2 PHASE ENERGIZED)	
AMBIENT TEMPERATURE -10~ 50°C [14°F ~ 122°F]	
INSULATION RESISTANCE 100 MOhm (UNDER NORMAL TEMPERATURE AND HUMIDITY)	
INSULATION CLASS B 130° [266°F]	
DIELECTRIC STRENGTH 500VAC FOR 1 MIN. (BETWEEN THE MOTOR COILS AND THE MOTOR CASE)	
AMBIENT HUMIDITY MAX. 85% (NO CONDENSATION)	

Please regard the application note at www.nanotec.com for further informations.

Shaft play is adjustable at the motor.

PIN NO	TYPE OF CONNECTION (EXTERN)		MOTOR	
	BIPOLAR	LEADS	WINDING	
1	A —	BRN	A	
2	A\ —	ORG	A\	
3	B —	RED	B	
4	B\ —	YEL	B\	

WIRING DIAGRAM

FULL STEP 2 PHASE-Ex., WHEN FACING MOUNTING END (X)

STEP	A	B	A\	B\		CCW
1	+	+	-	-		↑
2	-	+	+	-		
3	-	-	+	+	↓	↑
4	+	-	-	+		

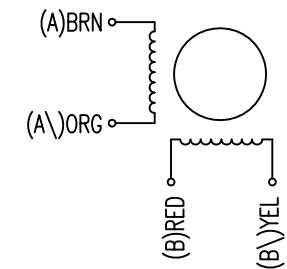

4	change tolerance	15.09.16	A.S.		APVD	S.R.	04.11.10	LINEAR ACTUATOR
3	change depth threaded hole	16.07.15	A.S.		CHKD			
2(3x)	UPDT. DATA	22.09.14	J.D.	Surface specification DIN ISO 1302	DRN	J.W.	04.11.10	DWG.NO
REV	DESCRIPTION	DATE	DRN	General tolerances DIN ISO 2768- cH	Work piece edge DIN ISO 13715	SIGNATURE	DATE	L4118S1404-T6x2-A25