

Front view and mounting

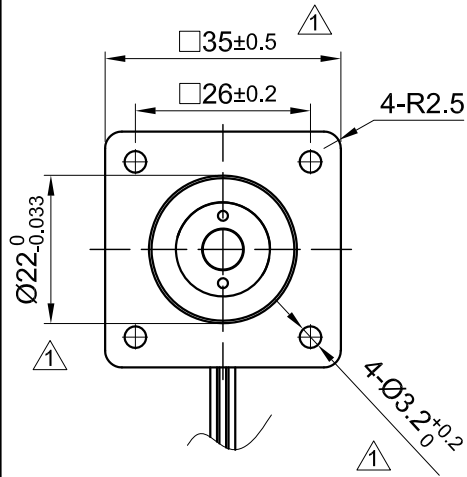

Side view

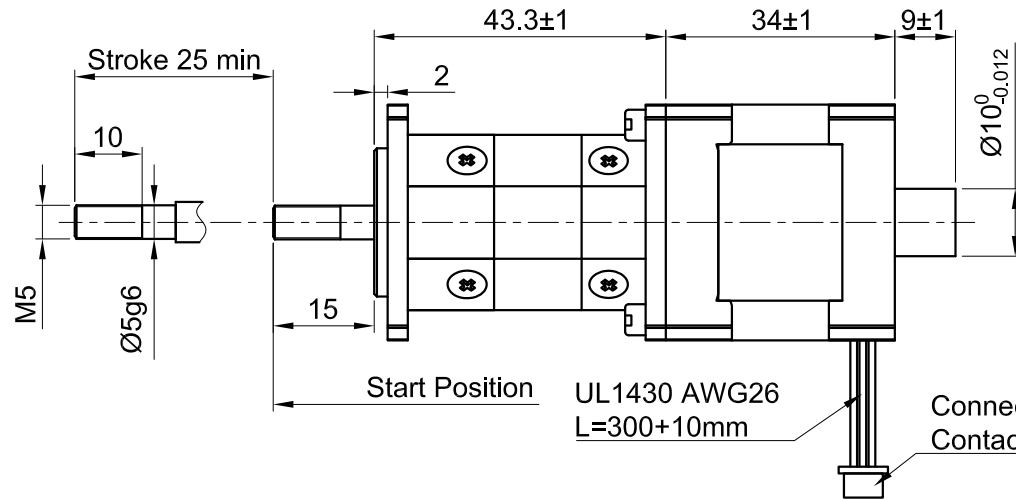

Rear view

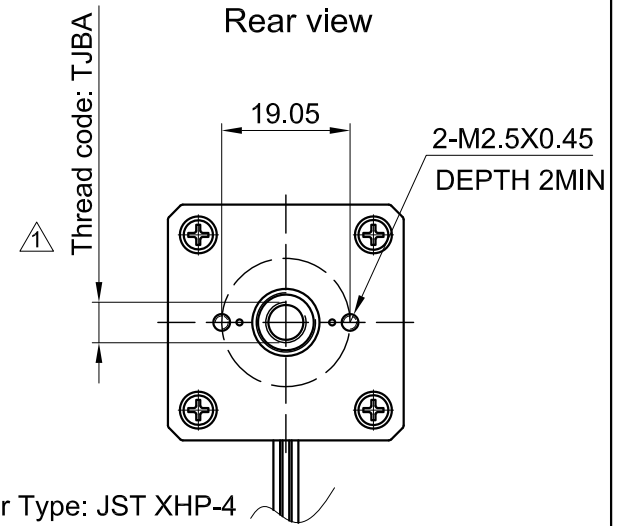

SPECIFICATION	BIPOLAR
AMPS/PHASE	1.2
RESISTANCE/PHASE (Ohms)@25°C	1.85±15%
INDUCTANCE/PHASE (mH) @1KHz	2.0±20%
SPINDLE LEAD (mm) [in]	1 [0.039]
THRUST (N) [lbf]	240[53.95]
RESOLUTION (mm/FULLSTEP)	0.005
STATIC THRUST (N) [lbf] (NO CURRENT)	>240
MAX. SPEED (mm/sec.) AT 48V	50
MAX. SPEED WITH MAX. THRUST (mm/sec.) AT 48V	5
WEIGHT (Kg) [lb]	0.2[0.44]
TEMPERATURE RISE: MAX.80°C (MOTOR STANDSTILL; FOR 2 PHASE ENERGIZED)	
AMBIENT TEMPERATURE -10~ 50°C [14°F ~ 122°F]	
INSULATION RESISTANCE 100 MOhm (UNDER NORMAL TEMPERATURE AND HUMIDITY)	
INSULATION CLASS B 130° [266°F]	
DIELECTRIC STRENGTH 500VAC FOR 1 MIN. (BETWEEN THE MOTOR COILS AND THE MOTOR CASE)	
AMBIENT HUMIDITY MAX. 85% (NO CONDENSATION)	

Please regard the application note at www.nanotec.com for further informations.

Shaft play is adjustable at the motor.

TYPE OF CONNECTION (EXTERN)	MOTOR		
	BIPOLAR	LEADS	WINDING
PIN NO			
1	A —	BK	A
2	A\ —	GN	A\ B
3	B —	RD	B
4	B\ —	BU	B\ A

WIRING DIAGRAM

FULL STEP 2 PHASE-Ex., WHEN FACING MOUNTING END (X)

STEP	A	B	A\ B	B\ A		CCW
1	+	+	-	-		
2	-	+	+	-		
3	-	-	+	+		
4	+	-	-	+		

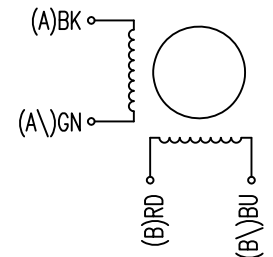

				 Nanotec [®] PLUG & DRIVE			APVD	G.S.	16.01.12	LINEAR ACTUATOR DWG.NO L3518S1204-T6x1-A25
1	Screw use TJBA, etc.	27.07.20	X T				CHKD	GYQ	16.01.12	
REV	DESCRIPTION	DATE	DRN	Surface specification DIN ISO 1302	General tolerances DIN ISO 2768-cH	Work piece edge DIN ISO 13715	DRN	L B	16.01.12	
							SIGNATURE	DATE		