

Front view and mounting

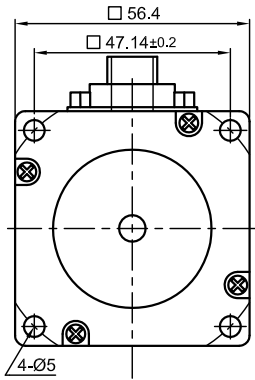

Side view

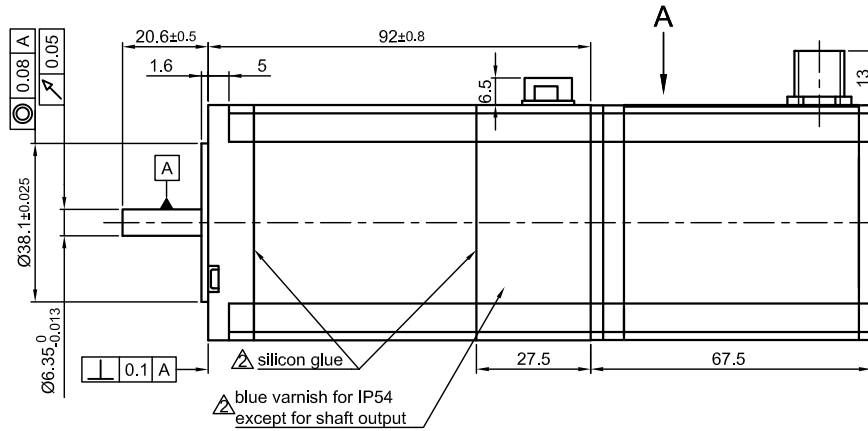

Rear view

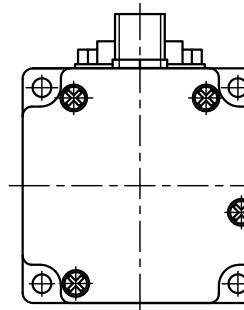

Top view A

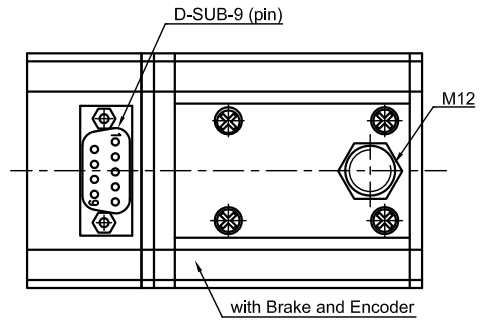

SPECIFICATION	CONNECTION	BIPOLAR PARALLEL
VOLTAGE (VDC)		3.38
AMPS/PHASE		2.82
RESISTANCE/PHASE (Ohms)@25°C		1.2 ± 10%
INDUCTANCE/PHASE (mH) @1KHz		5.1 ± 20%
HOLDING TORQUE (Nm) [lb-in]		1.7 [15.02]
DETENT TORQUE (Nm) [lb-in]		0.068 [0.602]
STEP ANGLE (°) ± ACCURACY		1.8 ± 5% (NON-ACCUM)
BACK-EMF (V) (300 U/min)		29.6
ROTOR INERTIA (Kg-m ²) [lb-in ²]		5.0x10 ⁻⁵ [0.171]
WEIGHT (Kg) [lb]		1.38 [3.04]

WIRING DIAGRAM

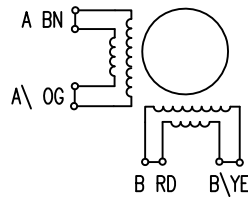

PERMISSIBLE RADIAL+AXIAL FORCE

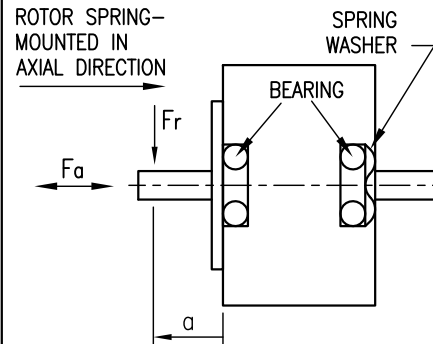

ENCODER M12		CABLE ▲
PIN	ASSIGNMENT	COLOR
1	A	WH
2	A\	BN
3	B	GN
4	B\	YE
5	GND 0V	GY
6	I	PK
7	I\	BU
8	Vcc +5V	RD
HOUSING	GND/SHIELDING	

MOTOR D-SUB-9	
PIN	ASSIGNMENT
1	A
2	A\
3	B
4	B\
5	NC
6	NC
7	BRAKE
8	BRAKE/GND
9	NC
HOUSING	GND/SHIELDING

FULL STEP 2 PHASE-Ex.,
WHEN FACING MOUNTING END (X)

STEP	A	B	A\	B\	CCW	CW
1	+	+	-	-	↓	↑
2	-	+	+	-	↓	↑
3	-	-	+	+	↓	↑
4	+	-	-	+	↓	↑

TEMPERATURE RISE: MAX.80°C (MOTOR STANDSTILL; FOR 2 PHASE ENERGIZED)	AXIAL-FORCE Fa (N)	Fa=15			
AMBIENT TEMPERATURE -10~ 50°C [14°F ~ 122°F]	DISTANCE a (mm)	5	10	15	20
INSULATION RESISTANCE 100 MOhm (UNDER NORMAL TEMPERATURE AND HUMIDITY)	RADIAL-FORCE Fr (N)	130	90	70	52
INSULATION CLASS B 130° [266°F]			AXIAL	RADIAL	
DIELECTRIC STRENGTH 500VAC FOR 1 MIN. (BETWEEN THE MOTOR COILS AND THE MOTOR CASE)	SHAFT PLAY (mm)	0.08	0.02		
AMBIENT HUMIDITY MAX. 85% (NO CONDENSATION)	AT LOAD MAX: (N)	4.5	4.5		

REV	DESCRIPTION	DATE	APVD
2	WITH VARNISH+SILICON GLUE	19.02.10	J.W.
1	COLOR OF CABLE	08.07.09	J.W.



AD5918L2804-EB

SCALE FREE	APVD	S.Ha.	04.08.08
X ±0.5	CHKD		
1PL ±0.2	DRN	J.W.	04.08.08
2PL ±0.1	SIGNATURE		
ANGLE ±30'			

STEPPING MOTOR

DWG.NO

AD5918L2804-EB