

Manual



SMC-46 (18. Oct. 2007)

Contents

	Page
1. Connections and functions	-3-
1.1 Inputs	-3-
1.2 Outputs	-5-
1.3 Buttons	-6-
1.4 Switches	-6-
1.5 Indications	-7-
2. Commissioning	-8-
3. Technical Data	-9-
4. HF-Radiation	-9-
5. Dimensions	-10-

New functions SMC-46-7 (with blue LED!)

We did improve the following

- Higher supply voltage from 24V to 72V (old Version: 48 V)
- Better protection against Under-, Overvoltage and against polarity reversal.
- Additional microstepmode 1/32 step for a smooth drive.
- No Fan.
- Blue Power LED for a better differentiation to the old version.

The only incompatibility is an inversion of the error-output. Because now you are able to identify cable brakes.

If you use this error output you need to invert your connection.

The last difference is the price:

Now the new version is only 198,80€ instead of 278,90€.

If you have any questions feel free to contact our sales team!

1. Connections and functions

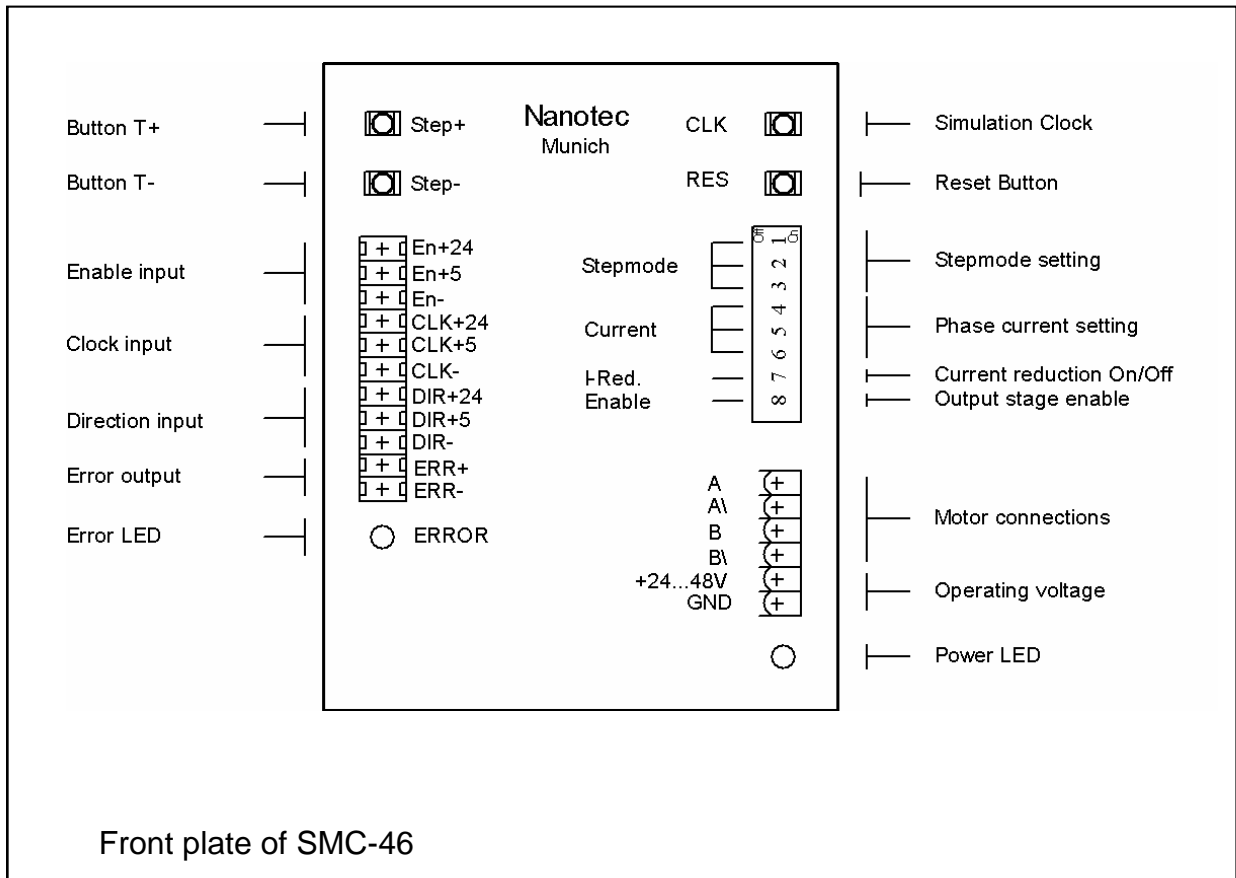

1.1 Inputs

a) 'Enable' input

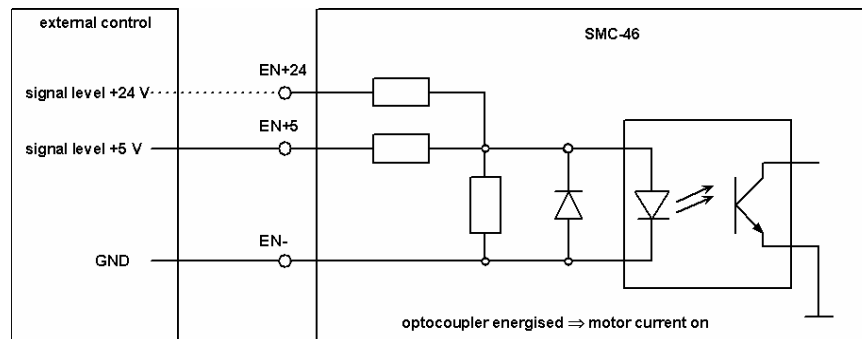

The motor current can be switched on and off with the help of the Enable input. The current values applied to the phases immediately before the current was switched off are fed to the phases when the current is switched back on. If the Enable input is not connected, the motor current is switched on and off by the Enable switch (see 1.4d).

b) 'Clock' input

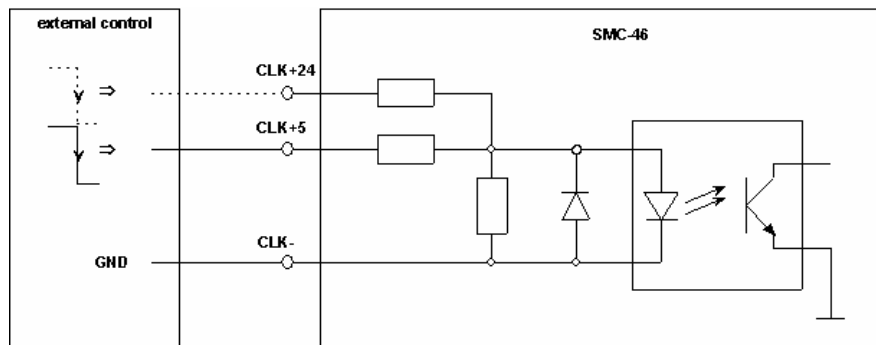

The phase current is stepped by one value on the falling edge of the Clock signal; the motor executes one step.

c) 'Direction' input

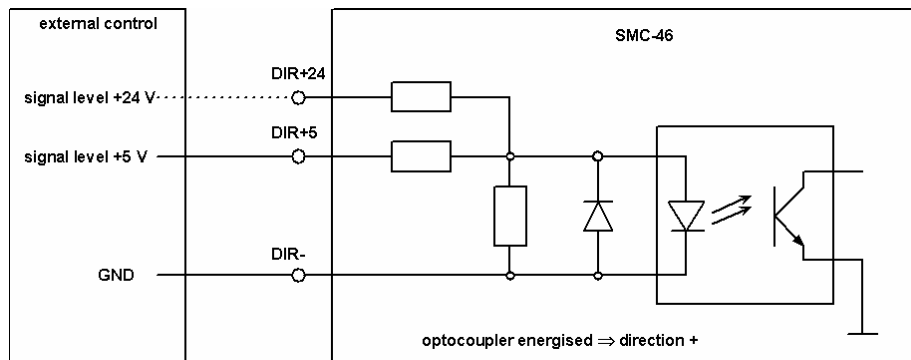

The Direction input determines the direction of motor rotation. There must be a pause of at least 120 μ s between the time at which the direction of rotation is changed and enabling of the Clock input.

d) Operating voltage

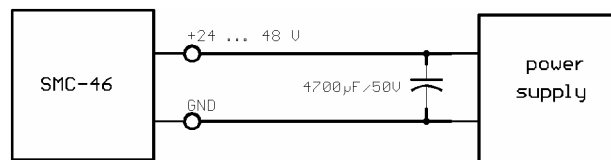

The operating voltage of the SMC-46 is in the range of 24-48 V DC. A load condenser of at least 4700 μ F/50V **must** be connected at the supply (available as accessories) in order to prevent overshoot beyond allowable voltage (e.g. for the brake applications). **Interchanging the terminals can damage the output stage.**

**Never disconnect the intermediate circuit if the power supply is on!
 Don't pull energised plugs!**

1.2 Outputs

a) 'Error' output

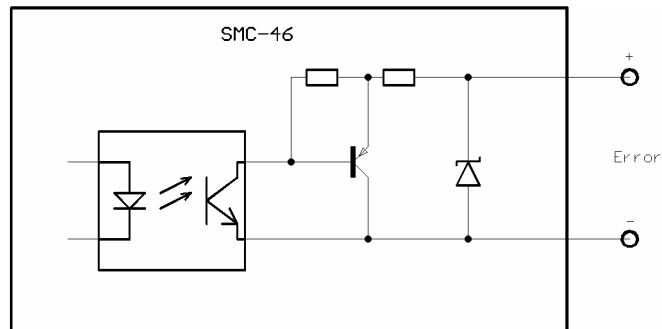

The Error output is activated when the following events occur:

- Temperature rise:
the output stage has overheated and was disabled.
- Short-circuit:
there has been a short-circuit between the motor phases or to GND.
The output stage was disabled automatically.

b) Motor connections

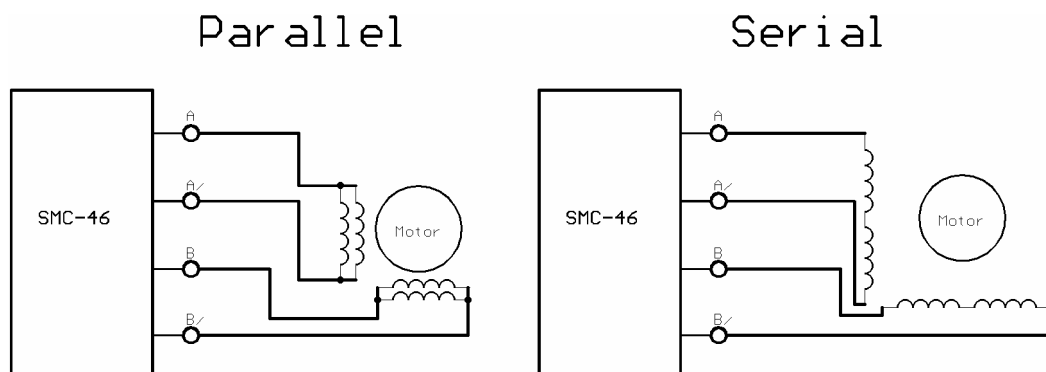

Refer to the data sheet of your stepper motor for the designations of your connecting cables. **Check the connections carefully since a wrong connection can result in the output stage being destroyed.**

Don't pull energised plugs!

1.3 Buttons

a) T+ and T- Buttons

The motor can be moved manually using pushbuttons T+ and T- (the direction of rotation depends on how the motor phases are connected).

b) Clock Sim. Button

The Clock input can be simulated by operating the Clock Sim. pushbutton (see 1.1c), and a step is executed every time it is operated (for simulation purposes only, the button is not debounced).

c) Reset Button

The control unit is reset by operating the Reset pushbutton, all inputs and outputs and displays and pushbuttons have no function, and the motor current is switched off. After the Reset pushbutton has been released, the SMC-46 is re-initialised, the motor is re-energised and reverts to its initial (home) position.

1.4 Switches

a) Stepmode (switches 1 to 3)

Stepping mode is set with switches 1 to 3. The following settings are possible in this instance.

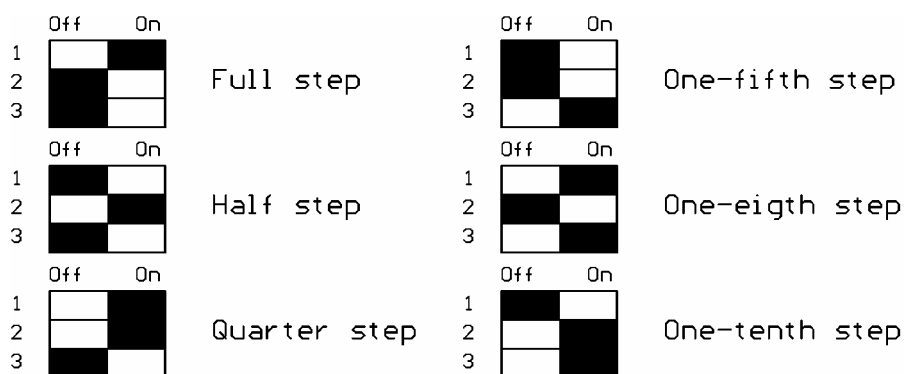

The set Stepping mode is applied following power-up or after a reset (via pushbutton).

b) Phase current (switches 4 to 6)

The phase current is set with switches 4 to 6 as shown in the diagram below.

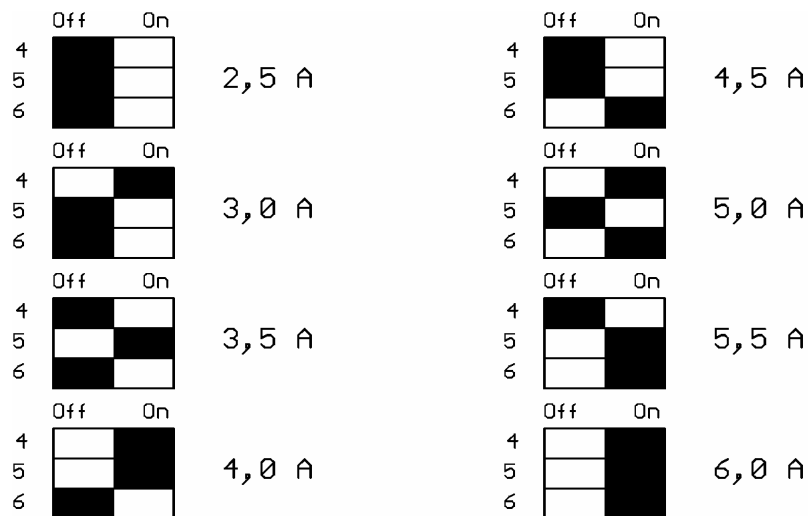

The set phase current is applied following power-up or after a reset (via pushbutton).

c) I-Red switch (current reduction, switch 7)

If this switch is at "On", current reduction is enabled. If the motor is at rest for a period of more than 80 ms, the phase current is lowered by 70%.

d) Enable switch (switch 8)

The Enable switch is used to switch the motor current on (On) and off (Off). When the motor current is switched back on, the motor windings are energised with the values applied immediately before it was switched off (see also 1.1a).

1.5 Indications

a) Power LED

The LED lights when the control unit is switched on

b) Error LED

The Error LED is activated when the following events occur:

- Temperature rise:
the output stage has overheated and was switched off.
- Short-circuit:
There is a short-circuit between the motor phases or to GND. The output stage was disabled automatically.

2. Commissioning

To commission the SMC-46, perform the following steps:

- 1) Connect the motor to the outputs provided for it (see 1.2b).
- 2) Connect the power supply (including the charging capacitor) to the terminals provided for it (see 1.1e).
- 3) Set the required Stepping mode (see 1.4a) and phase current (see 1.4b). If you do not want the current to be reduced when the motor is at rest, set switch 7 to Off, and switch 8 (Enable) must be in the On position.
- 4) Switch on the operating voltage. The red "Error" LED comes on briefly after power-up. If the red LED stays on, switch off the control unit immediately and check the connections.
- 5) The SMC-46 is now ready for operation; with pushbuttons T+ and T- you can move the motor manually (test run).
- 6) Following successful commissioning, you can perform the remaining connections (after switching off the control unit) such as Clock, Direction etc. and turn the SMC-46 back on.

3. Technical Data

Operating voltage	24 to 48 V DC
Phase current	2,5 to 6 A
Current setting	through DIP-Switch
Type of Operation	Bipolar-Chopper-Driver
Operating mode	Full step Half step Quarter step One-fifth step One-eighth step One-tenth step
Step setting	through DIP-Switch
Step frequency	0 to max. 50 kHz
Manual running	through buttons T+ and T-
Output	Optocoupler output current max. 50 mA output voltage max. 35 V
Inputs	5 V and 24 V optocoupler 10 mA input current
Current reduction	0 and 70 % through DIP-Switch
LEDs	Power (Operating voltage) Error (Excess temperature, Short circuit)
Temperature range	0 to 40° C
Type of connections	Screwed clamp plugs
Type of mounting	DIN-rail mounting Direct screw connections
Dimensions	106 x 94 x 78 (L x B x H)

4. HF Radiation

Due to the clocked method of operation of the SMC-46, electromagnetic AC fields are generated around live conductors, especially around motor and supply cables. These fields can interfere with other devices. At the same time, the SMC-46 might be disturbed by the same type of field generated by other devices.

Suppression measures:

- Screen cables, run the screen connection on both sides to a short earth
- Use twisted pair cables
- Keep power supply and motor cables as short as possible
- Run large areas of the output stage housing to a short earth
- Run large areas of motors to a short earth
- Run supply, motor and control cables separately

5. Dimensions

