

Front view and mounting

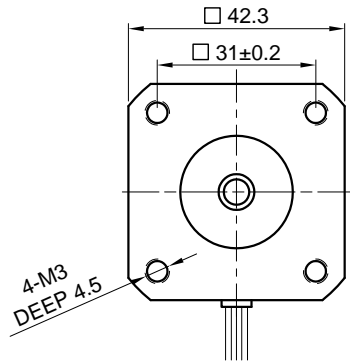

Side view

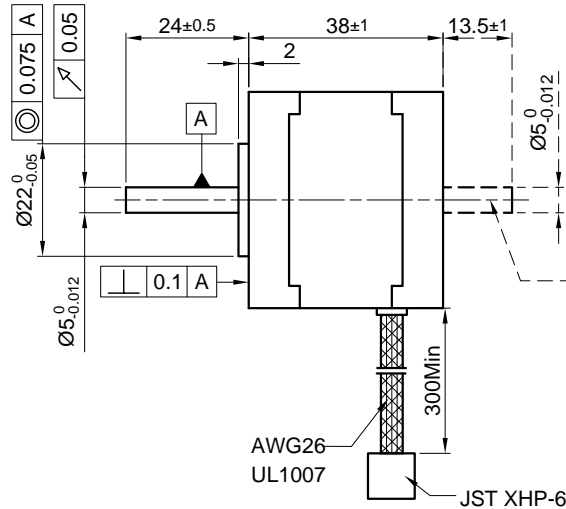

Rear view

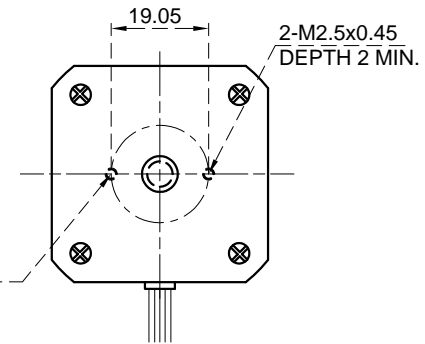

SPECIFICATION	CONNECTION	
	UNIPOLAR OR BIPOLAR-1 WINDING	BIPOLAR SERIAL
VOLTAGE (VDC)	6.65	9.4
AMPS/PHASE	0.7	0.49
RESISTANCE/PHASE (Ohms)@25°C	9.5±15%	19±15%
INDUCTANCE/PHASE (mH) @1KHz	8.0±20%	32±20%
HOLDING TORQUE (Nm) [lb-in]	0.28 [2.478]	0.396 [3.505]
DETENT TORQUE (Nm) [lb-in]	0.98x10 ⁻² [8.673x10 ⁻²]	
STEP ANGLE (°)	1.8	
STEP ACCURACY (NON-ACCUM)	±5%	
ROTOR INERTIA (Kg-m ²) [lb-in ²]	5.7x10 ⁻⁶ [1.95x10 ⁻²]	
WEIGHT (Kg) [lb]	0.24 [0.53]	
TEMPERATURE RISE: MAX.80°C (MOTOR STANDSTILL; FOR 2 PHASE ENERGIZED)		
AMBIENT TEMPERATURE -10~ 50°C [14°F ~ 122°F]		
INSULATION RESISTANCE 100 MOhm (UNDER NORMAL TEMPERATURE AND HUMIDITY)		
INSULATION CLASS B 130° [266°F]		
DIELECTRIC STRENGTH 500VAC FOR 1 MIN. (BETWEEN THE MOTOR COILS AND THE MOTOR CASE)		
AMBIENT HUMIDITY MAX. 85% (NO CONDENSATION)		

PERMISSIBLE RADIAL+AXIAL FORCE

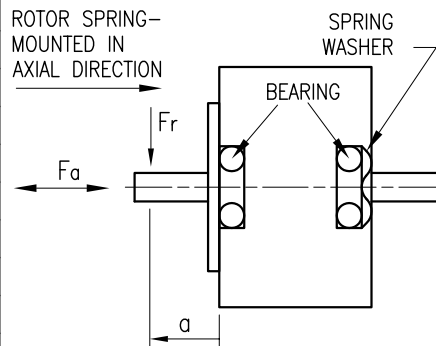

AXIAL-FORCE Fa (N)	Fa=7			
	5	10	15	20
DISTANCE a (mm)	5	10	15	20
RADIAL-FORCE Fr (N)	58	36	26	20
		AXIAL	RADIAL	
SHAFT PLAY (mm)	0.08	0.02		
AT LOAD MAX: (N)	4.5	4.5		

TYPE OF CONNECTION (EXTERN)	MOTOR		
	UNIPOLAR	BIPOLAR	
	1WINDING	SERIAL	
A ---	A ---	A ---	CONNECTOR PIN NO. 1
COM ---	COM ---		LEADS 5 BRN
A\ ---		A\ ---	3 ORG
B ---	B ---	B ---	2 RED
COM ---	COM ---		6 WHT
B\ ---		B\ ---	4 YEL

for >speed ←
for <speed ←

FULL STEP 2 PHASE-Ex., WHEN FACING MOUNTING END (X)

STEP	A	B	A\	B\	CCW	CW
1	+	+	-	-	↓	↑
2	-	+	+	-	↓	↑
3	-	-	+	+	↓	↑
4	+	-	-	+	↓	↑

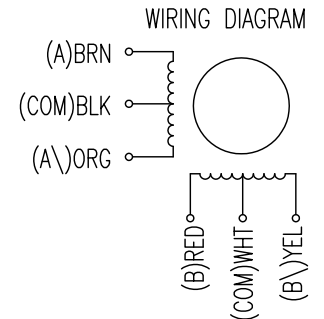

REV	DESCRIPTION	DATE	APVD	NANOTEC:	SCALE	FREE	APVD	S.H.a.	26.02.07	STEPPING MOTOR	
					X	±0.5	CHKD				
					1PL	±0.2	DRN	J.W.	29.11.06	DWG.NO	
					2PL	±0.1	SIGNATURE		DATE		
					ANGLE	±30'					ST4118M0706